



Enduring Quality for Better Living

## **PREFINISHED 3-LAYER ENGINEERED HARDWOOD FLOORING INSTALLATION AND MAINTENANCE MANUAL**

The Installation and Maintenance Manual listed below applies only to the Signature Floorboards™ purchased on or after September 1, 2003.

### **SPECIFICATIONS**

Signature Innovations' flooring (Signature Floorboards™) consists of three perfectly formed layers of wood glued in a manner as to prevent swelling and/or shrinking.

#### **1. THE TOP LAYER**

This layer is made of deciduous wood such as oak, beech or birch. The surface is protected by a tough, high quality, and abrasion resistant transparent lacquer. The finish combines our exclusive 6 coats of acrylic finishing process with aluminium oxide, second in hardness only to diamonds, to provide unsurpassed protection against normal wear. The last two coatings are UV-hardened, making it more resilient than any finish that could be applied on-site. The lacquers used are environmentally safe and non-allergenic.

#### **2. THE MIDDLE LAYER**

This layer is made of spruce, pine or similar coniferous wood. It is formed of narrow (1" long and 1/3" wide) tabs. Such construction prevents swelling and/or shrinking of the middle layer from changing the size of the entire board.

#### **3. THE BOTTOM LAYER**

This layer is made of poplar, alder, aspen, pine, etc., and its primary function is to compensate the tensions in the upper layers.

**All three layers are glued together in such a manner as to ensure reliability and durability as well as damp resistance.**

### **USE**

Signature Innovations' flooring is environmentally safe and non-allergenic. It is made of 3 layers of solid wood with the use of reliable glues and lacquers. It is safe for use at homes, condominiums, basements and other residential areas. By using only the highest quality wood, we provide you with the highest comfort. The thickness of the top layer (1/6") allows for restoration by refinishing 2 or 3 times. The flooring is:

- Hygiene class E 1 · Formaldehyde free · Fire resistant · Environmentally friendly (ECO PRODUCT)

#### **Radiant-Heating Systems**

Signature Floorboards™ can be installed over radiant-heated systems, however Signature Innovations, LLC, does NOT recommend such use. Furthermore, Signature Innovations, LLC, will not honor any warranties for Signature Floorboards™ installed over any radiant-heating systems.

### **STORAGE AND TRANSPORT**

- The boards should be transported in their original packaging, protected from mechanical damage and moisture.
- The boards should be stored in their original packaging and in storage rooms that are dry and ventilated.
- Individual packages may be stacked on top of one another, provided the bottom package rests on a flat and dry surface. If they are stacked perpendicularly, there should be at least 4 packages next to one another.
- Improper transportation and/or storage may result in damage to the boards.

## GENERAL INSTALLATION

- All flooring boards should be installed according to the Installation Manual (see below).
- Although each Signature Innovations, LLC, floorboards (hereinafter Signature Floorboards™) are covered by a 25 year Limited Lifetime Warranty, however, warranty coverage may be lost due to failure to strictly follow all installation instructions and recommendations or the use of improper materials or tools. **READ ALL INSTRUCTIONS CAREFULLY.**

**NOTE:** Beech and Maple expand and contract more than other species of wood. Thus, there is a greater risk of gaps appearing in the floor. This is not a manufacturing defect but should be taken into consideration when choosing these species for your hardwood floor.

**IMPORTANT!** It is recommended that the boards be stored in the room where they will be installed for at least 48 hours prior to installation. **DO NOT** open flooring packages until ready to begin installation. Inspect boards as you go. Signature Floorboards™ are sealed at the factory with 8% –10% moisture content. Opening cartons to acclimate the flooring (as with some solid strip flooring) could result in a difficult installation. As an installer, it is your responsibility to be aware of the grade and moisture-content of the room and subfloor. Each floorboard should be inspected to insure that is free of factory damage or manufacturing defects. Floorboards that are unusable due to factory damage or manufacturing defects should be set aside for replacement.

- The warranty is void when floorboards with visible defects have been installed.

### Subfloor Specifications:

- The surface of the subfloor must be level to within 1/8" in an 8 ft. radius.
- Concrete subfloors must not contain more than 1.5% moisture on a dry-weight basis.
- Moisture content of wood subfloors should be between 6-10% Moisture Content (MC).
- The subfloor must be clean.
- Relative humidity range at the job site should be 45-60%; temperature setting should be within 15°F of normal operating point.

### The following should be avoided:

- Installing the boards in humid, non-ventilated rooms before "damp" works (plastering, painting),
- Installing the boards in rooms where they may be susceptible to mechanical damage, aggressive chemicals, water and/or other substances,
- The use of abrasive substances on the floor such as broken glass, sand, metal, etc.
- Moving heavy furniture on the floor without the use of felt pads on its legs.
- The use of rugs with solid rubber or vinyl backings.

## CLASSES

**EXTRA** – knotless wood with similar patterns of rings and uniform shades of planks.

**STANDARD** – wood with planks of slightly different shades with possible single knots of maximum diameter 1/6".

**NATURAL** – wood with planks of different shades and knots of maximum diameter 2/3".

**CLASSIC/RUSTIC** – wood with random planks. The pattern of shades and knots should be checked before purchase (definitely before installing).

## INSTALLATION MANUAL

### PREPARATION

#### Attention!

Inspect **ALL** materials carefully **BEFORE** installation. Warranties **DO NOT** cover materials with visible defects once they are installed.

#### Important!

**Do not open flooring packages until you are ready to begin installation. Read the following instructions before starting the flooring installation. The home should remain at 45-60% (RH) year round.**

It is the responsibility of the installer/owner to determine if the job site subfloor and job site conditions are environmentally acceptable for hardwood floor installation (see Subfloor Specifications listed above). **Signature Innovations, LLC, declines any responsibility for hardwood floor failure resulting from or connected with subfloor moisture, sub-surface or job site damage or deficiencies after wood flooring has been installed.**

#### Inspection of Materials:

PRIOR TO STARTING THE INSTALLATION OF ANY FLOOR, THE INSTALLER SHOULD INSPECT ALL THE MATERIAL AND DETERMINE THAT IT MATCHES THE WORK ORDER FORM. CHECK THE QUANTITY AND PRODUCT ITEM NUMBER AS WELL AS THE TYPES AND QUANTITY OF ADHESIVES, NAIL, TROWELS, AND OTHER SUNDRY ITEMS.

## **Description:**

**Signature Floorboards™** are a precisely milled hardwood product. It is tongue and grooved on the ends and sides. Signature Floorboards™ are engineered for added dimensional stability. **Recommended installation method for Signature Floorboards™ is a floating installation system**, (however, Signature Floorboards™ can also be stapled down or glued down, if necessary).

## **General Conditions:**

It is necessary that heating or air conditioning systems, if present, be operable and in service for at least two weeks prior to starting installation. Humidity range for the job site should be 45-60% and the temperature setting to within 15°F of normal living conditions.

**NOTE:** Do not install cabinets or walls on top of Signature Floorboards™.

## **Tools:**

The required tools for floating installation of Signature Floorboards™ include a square, hammer, hand or power saw, wood or plastic wedges (or equivalent 1/2" spacers), chalk line, Signature Wood Glue™ or parquet glue class DIN-D3 with increased water resistance (Poly vinyl acetate), a tapping block, and assembling rod. **Remember to always use EYE PROTECTION.**

## **Sub-floor Conditions & Floor Underlayment:**

Signature Floorboards™ can be installed over any DRY, sound, level surface, regardless of type, when using the floating method of installation. **Signature 2-in-1 Duo™** (100% moisture resistant polyethylene film and foam in one) protects the floor from moisture and provides cushion between the subfloor and the wood floor. The use of Signature 2-in-1 Duo™ floor underlayment is required for warranty.

## **Sub-floor Dryness:**

**SUB-FLOOR MUST BE DRIED.** New concrete sub-floors should be cured to a hard, dry, non-powdery finish. All concrete subfloors, on or below grade, should be tested for moisture content before installation of Signature Floorboards™ begins.

## **Make certain building interior and sub-floor are dry:**

Interior walls should be dry enough to be painted and at a room temperature of 60°F. minimum. A relative humidity of 45-60% should be provided before any installation is begun. To check for dryness, use the standard rubber mat or taped plastic test. Remove after 24 hours, then visually inspect for moisture. If moisture is present, do not install. All concrete sub-floors on or below grade can also be tested using a commercial moisture meter or commercial concrete encounter or meter (Check floor in several locations). Consult with your local Signature Floorboards™ distributor or retailer for geographic variances.

New wood type sub-floors should also be checked for moisture using a moisture meter. In general, wood or plywood sub-floors should not exceed 8% moisture content, or 3% moisture content difference between wood flooring and sub-floor. Check with your local distributor or retailer for your geographical variances.

## **Sub-floor Flatness:**

The surface of the subfloor must be level to within 1/8" in an 8 ft. radius. If subfloor prep work is required, "hills" should be sanded down and "valleys" filled with an underlayment patch, developed by a reputable manufacturer for use with hardwood flooring. Do not sand sub-surfaces such as vinyl or synthetic tiles that may contain asbestos. For small depressions, less than 1/4 inch, it is possible to use dry sand as a leveler. Small cracks and chips in concrete nail holes or hammer dents in wood and small gaps between underlayment sheets are not a problem with the floating installation method.

## **Sub-floor Preparation:**

As part of your sub-floor preparation, remove any existing base, shoe mold, or doorway thresholds. These items can be replaced after installation, but should be replaced in such a way **to allow at least 1/2" "room for expansion"** around the perimeter of the room. All door casings should be notched out or undercut to allow 1/2-inch room for expansion and to avoid difficult scribe cuts. This is easily done by placing a piece of Signature Floorboards™ on the sub-floor as a height guide for your handsaw.

*Note: In large areas measuring more than 24 lineal feet, use 1/4" expansion for each 12 linear feet width and length.*

# **INSTALLING THE FLOOR**

## **Floating Installation Method**

1. Measure the room and plan laying the boards so that the last row is not narrower than 2.5" and the first and the last boards are not shorter than 20".
2. Make sure that the floor is flat. It is best done by putting the edge of the floorboard on the floor; eventual gap should not exceed 1/12" at any point.
3. Install Signature 2-in-1 Duo™ floor underlayment (100% moisture resistant polyethylene film and foam in one). The use of Signature 2-in-1 Duo™ in Floating installation is required for warranty. Signature 2-in-1 Duo™ is comprised of 39 inches of underlayment plus an 8-inch overlap flap. The overlap flap guards the flooring from moisture at the seams, where the rows of underlayment are laid side by side.

- Layout 1st row of underlayment (blue film side down, white foam side up) with the overlap facing the opposite wall.
  - Lay 2nd row of underlayment next to first. Make sure the overlap is under the foam connecting both sides of the underlayment. There is no glue or stick strip required to connect both sides of the underlayment.
  - Continue this procedure row by row until the entire floor area is covered.  
When connecting a new roll of underlayment to the end of the roll you are working on, or for repairing any tears or cuts in the underlayment; overlay the butt joints or the damaged area with a spare piece of overlap plastic film. This spare piece should overlay by approx. 8 inches. Hold the spare piece in place with tape.
  - Cover the entire floor area to provide a secure enclosure for the flooring.
4. Once the Signature 2-in-1 Duo™ floor underlayment has been installed over the subfloor, the jobsite is ready for the Signature Floorboards™. Never open the bundles until ready to start the installation process. When the decision is made on the direction the boards will run, start at one side wall (see Fig. 1) with the first row of boards, allowing a 1/2" expansion along side and end walls (see Fig. 2) with the use of wood wedges (equivalent spacers). If the starting wall is out of square, it is recommended the first row of boards be scribed to allow for 1/2" of expansion and a straight working line.
  5. The manner of the first row of Signature Floorboards™ is very important. Place the first row of boards with the groove nearest the wall, keeping 1/4" distance from the wall. Put the spacer blocks between the wall and the boards; these should be put at each end of every board, not more than 40" from each other (see Fig. 2). Put the glue, Signature Wood Glue™ or parquet glue class DIN-D3 with increased water resistance (Poly vinyl acetate) in the groove on top of each board and clench firmly in place (see Fig. 3). Wipe any excessive glue with the damp cloth.
  6. Signature Floorboards™ must be side and end glued using Signature Wood Glue™ or parquet glue of class DIN - D3, with increased water resistance (Poly vinyl acetate) or waterproof. The professional grade glue should be used for adhering the floorboards to the floor (glue down installation, if applicable).
  7. The second row of boards and the next ones should be laid brick alike. Each of the following rows should start with the piece of board cut off from the last board in the previous row, provided it is at least 20" long (see Fig. 4). The boards should be cut using handsaw or electric one. Put the glue on the entire length of the groove and clench firmly. To assist, use a hammer to hit the outside edge through a block made of hard wood, at least 12" long (see Fig. 5). Please remember to carefully press the boards to reach maximum tightness.
  8. After each board is installed, wipe off any excessive glue and check for the eventual gap. If the gap is larger than 1/12", repeat the clenching procedure as described above.
  9. Installing the Last Row: Most often the last row does not fit in width. When this occurs, follow this simple procedure: lay a row of boards, unglued, tongue toward wall, directly on top of last installed row (see Fig. 6). Take a short piece of Signature Floorboard™ with the face down and the tongue side against the wall. Draw a line with a pencil along the row moving down the wall. The resulting line gives the proper width for the last row which, when cut, can then be wedged into place using a crow bar (see Fig.7) or assembling rod. Make sure when the installation is complete that wedges and spacers are removed and the expansion space is covered with an appropriate molding. Always attach the trim to the wall or vertical object (see Fig. 8) and never to the Signature Floorboards™.
  10. Following proper installation of the floor, allow ample time for the glue to harden (approximately 2-3 hours) at which time the spacer blocks may be removed.

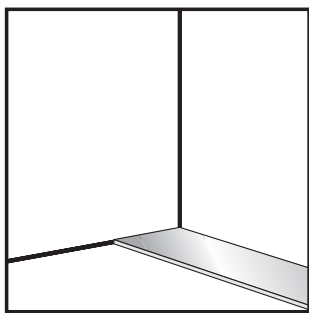

(Fig. 1)

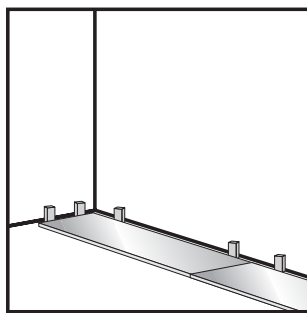

(Fig. 2)

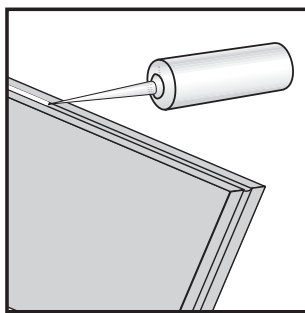

(Fig. 3)

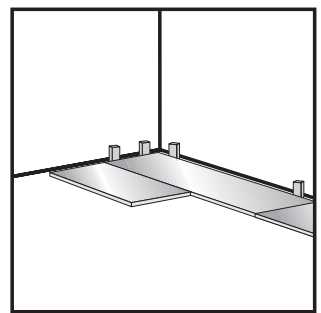

(Fig. 4)

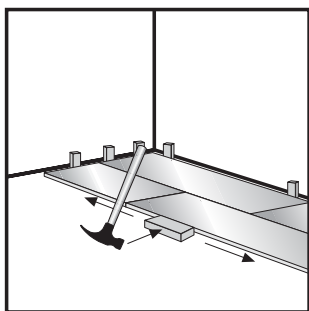

(Fig. 5)

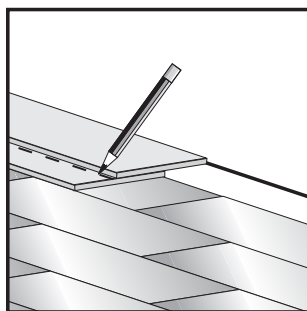

(Fig. 6)

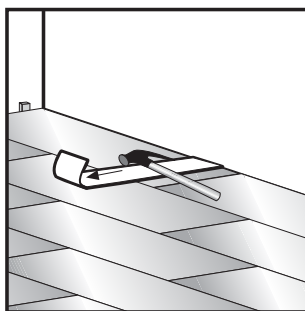

(Fig. 7)

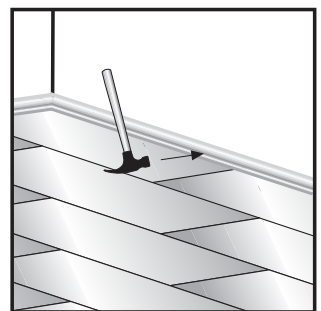

(Fig. 8)

**Please note:**

- Do not install any products with visible defects.
- The use of touch-up putty and/or repair paste to cover small cracks should be considered normal in wood flooring installation.
- For additional information on installation of Signature Floorboards™, please write to the following address:

**SIGNATURE INNOVATIONS, LLC**  
**P.O. Box 464**  
**Wood Dale, Illinois 60191-0464**

**MAINTENANCE**

- Signature Floorboards™ are protected with 6 layers of acrylic lacquer (the top two UV-hardened) and therefore are very easy to maintain. To clean, simply dust with a vacuum cleaner or soft dry cloth. For additional maintenance, use "for hardwood floors" approved cleaners only.
- The floor should be protected from excessive dirt, water, chemicals, and and/or other abrasive materials, etc.
- Maintenance procedures:
  - a) **Cleaning** – use soft cloth with "for hardwood floors" approved cleaners only. Do NOT use water, oil soap and/or ammonia based cleaners.
  - b) **Flooding** – use dry cloth to remove excessive water immediately,
  - c) **Stains:**
    1. Asphalt, oil, rubber, shoe polish, chocolate - remove with a petroleum based solvent.
    2. Lipstick, ink - remove with a 1:1 mix of water and rubbing alcohol.
    3. Stearine, chewing gum, wax - chill (e.g. with ice-pack), then gently scrape off.
    4. Paints, chemically bonding adhesives - remove immediately then wipe with petroleum.
- Deep scratches can be removed by scraping and filling with repair paste or by replacing the board (this should be done by a professional installer).

---

**Congratulations On Your New Flooring!**  
**Here Are Some Important Tips To Help You Protect Your**  
**New Hardwood Floor**



**Excessive amounts of water and wood don't mix**

Wood is a natural material that swells when it absorbs water and shrinks when it dries. Wipe up spills immediately to keep your floor unmarked, smooth and level. Never use water to clean or mop your floor. Excessive amounts of water and wood don't mix. Do not use rugs with solid rubber or vinyl backings directly on your hardwood floor. Let your floor breath.



**Avoid spike heels and furniture glides**

Spike heels are damaging to hardwood flooring. They strike a floor with more force per inch than an elephant's foot. Spike heels in disrepair are especially harmful to your floor. Round-headed chair glides and narrow wheels on furniture legs are also damaging. They can scratch or permanently dent your floor. Spread the weight. Use commercially made felt protectors or furniture coasters to prevent scratches and dents.



**Grit is one of the biggest dangers to your floor**

Tracked-in dirt is like sandpaper on hardwood flooring. Use a walk-off or entry rug at every outdoor entrance to catch grit. Vacuum or shake out regularly.

Use of floor maintenance products not specifically manufactured for use on hardwood floors may damage your floor and will void your warranty.



**P.O. Box 464**  
**Wood Dale, Illinois 60191-0464**  
**www.signatureinnovations.com**



Enduring Quality for Better Living

*Signature Innovations, LLC, hardwood flooring is manufactured from the highest quality raw materials. European craftsmen create this durable and beautiful flooring in the world's most technically advanced hardwood flooring factories. A full range of warranties provided by the European manufacturer also support our product.*

The warranties listed below apply only to the Signature Floorboards™ purchases made on or after September 1, 2003.

## **25 YEAR LIMITED WARRANTY PROGRAM**

### **FULL WARRANTIES**

Signature Innovations, LLC, is dedicated to providing you with only the highest quality European wood flooring and our commitment to research and development allows us the ability to offer our customers full and inclusive warranties for our entire line of wood flooring. The Warranties described below apply to residential applications only, and are given to the original purchaser only, and ARE SUBJECT TO THE PROCEDURES, LIMITATIONS, DISCLAIMERS AND EXCLUSIONS SET FORTH HEREIN. The Warranties cover only approved product applications as recommended in the Signature Innovations, LLC Installation and Maintenance Manual.

### **25 YEAR LIMITED LIFETIME STRUCTURAL INTEGRITY WARRANTY**

Signature Innovations, LLC, warrants to the original purchaser that Signature Floorboards™ (pre-finished three layer hardwood flooring) you have purchased will remain free from manufacturing defects in lamination, assembly, milling, dimension and grading for the lesser of twenty-five (25) full years or as long as the original purchaser owns the home (residential floor only). Wood flooring, being a natural product, will continue to expand and contract through heating and non-heating seasons. Properly installed Signature Floorboards™ may consequently experience some separation between boards at different times during the year. If separations do occur, they are considered normal, and are not covered by this warranty.

### **25 YEAR LIMITED LIFETIME FINISH WARRANTY**

Signature Innovations, LLC, warrants to the original purchaser that the acrylic with aluminum oxide UV-hardened lacquer surface finish used on all Signature Floorboards™, from the date of purchase, when used under recommended residential traffic conditions and maintained as recommended in the Signature Innovations, LLC, Installation and Maintenance Manual, will not wear through or separate from the wood for the lesser of twenty-five (25) full years or as long as the original purchaser owns the home (residential floor only). This warranty extends only for wear areas, which cover at least ten percent (10%) of the surface area of the installed floor. Gloss reduction is not consider wear through, therefore is not covered under the finish warranty.

Finish warranties exclude any indentations, scratches or damage caused by lack of proper maintenance, misuse, negligence, accident, spiked heel shoes, pets, insects, water, moisture, erosion, pebbles, sand, tracked-in dirt and grit, or other abrasives or insufficient protection on furniture, wet mopping or failure to follow Installation and Maintenance Manual.

### **MOISTURE WARRANTY**

Signature Floorboards™ are warranted against warping, cupping, buckling due to water migration up through the concrete, only when properly installed over Signature 2-in-1 Duo™ floor underlayment and jointly glued with Signature Wood Glue™ (UZIN MK-33). This warranty only applies if the subfloor is tested and the flooring is installed in accordance with all installation instructions. So it is critical that before installation, all subfloors are inspected and tested for dryness or moisture problems. Written documentation regarding your pre-installation tests will be required to honor your claim. In the event that floor is installed using any other floor underlayment or wood glue, this warranty is voided.

### **ADDITIONAL WARRANTIES**

Signature Innovations, LLC, (hereinafter "Signature") warrants to the original purchaser that all of our Signature Floorboards™ meet our highest quality standards. You and/or your installer should carefully inspect the flooring before installation. Any uncut pieces that appear to have defects should be returned to the original place of purchase and those pieces that do not meet our specifications will be replaced at no cost to you. Since this is a natural wood product, there will be variation in color, tone, and grain. Such variations are not covered by this warranty. Further, this warranty provision is void upon installation of the flooring.

If in the unlikely event any portion of the original purchaser's floor should fail with respect to the provision of these warranties, Signature at its sole option, will repair, refinish or replace said portion at no cost to the original purchaser with the same or equivalent product. In the unlikely event Signature is unable to correct the failure after a reasonable number of attempts, Signature will refund (if requested) the purchase price for the portion of the floor that failed. ANY CLAIM FOR WARRANTY COVERAGE MUST BE MADE WITHIN 90 (NINETY) DAYS OF THE DATE UPON WHICH THE DEFECT FIRST BECAME KNOWN OR FIRST SHOULD HAVE BEEN DISCOVERED. ALL CLAIMS MUST BE MADE IN WRITING. PLEASE NOTE THAT IN ORDER TO MAKE ANY CLAIM UNDER THIS WARRANTY, EVIDENCE OF THE PURCHASE DATE AND THE IDENTITY OF THE ORIGINAL PURCHASER AND INSTALLATION LOCATION MUST BE PROVIDED AND WITHOUT SUCH PROOF, NO WARRANTY COVERAGE WILL APPLY. WE STRONGLY RECOMMEND THAT YOU KEEP THIS INFORMATION TOGETHER WITH INSTALLATION AND MAINTENANCE MANUAL AND YOUR RECEIPT IN A SAFE AND SECURE PLACE. To file a claim, first contact the Signature retailer where the original purchase was made. If the retailer is unable to satisfy the claim, contact Signature Innovations, LLC, P.O. Box 464, Wood Dale, IL, 60191-0464, Attn: Claims Department. Signature reserves the right to have a designated Signature representative inspect the flooring and to have samples removed for technical analysis.

In the event that Signature is obligated, or elects, to repair, replace or reinstall warranted floorboards, Signature shall in no manner be obligated to provide for or incur the cost of removing or reinstalling the defective flooring or resurfacing or refinishing the replaced or surrounding flooring or to provide for the cost thereof unless and to the extent expressly provided in the Limited Warranty Program above. No obligation to replace or repair shall extend to any subfloor materials, adhesives, underlayments, supplies or other items consumed in the course of removal, installation or refinishing.

- Signature Warranties are not transferable.
- No installer, retailer, dealer, distributor, agent or employee has authority to alter in any way the obligations, limitations or coverage of any Signature warranty. No agreement to repair or replace shall in any event act to extend the period of coverage of any warranty provided.

#### **WARRANTY DISCLAIMERS AND EXCLUSIONS**

- Color, grain pattern and/or texture variations in wood flooring are a natural occurrence due to species, age or character of flooring and exposure to UV light or sunlight. Installed flooring will change in coloration over time, and this is also a natural characteristic of wood products for which no warranty is provided. Exposure of all or portion of the installed flooring to direct or indirect sunlight may cause variation in color, and such variations are not covered under warranty. Area rugs should be moved occasionally because they block sunlight and may give the appearance of discoloring under the rug. For these reasons, new and/or replacement flooring may not match display sample and/or existing flooring. Gloss reduction is not considered surface wear and is not covered by warranty.
- Signature is not responsible for color variation of product or samples for the consumer matching flooring to other wood products such as cabinets, stair railing, trim and moldings.
- Naturally occurring wood characteristics such as variations in grain, color, mineral streaks and knots are not considered defects.
- Signature Floorboards™ should be installed in environments of 45% to 60% relative humidity to prevent possible damage not covered by warranty. Installation of a humidifier or dehumidifier will be necessary. The floor is designed to perform in an environmentally controlled structure.
- Signature declines all warranties for Signature Floorboards™ installed over any radiant-heating systems.
- Damage due to the use of area rugs with solid rubber or vinyl backings is excluded from Signature warranties.
- Installations must be performed in accordance with all Signature installation instructions.
- It is the responsibility of the installer and/or the owner to inspect boards prior to installation. Signature accepts no responsibility for costs of product or labor when boards with visible defects have been installed.
- Damage due to water and/or moisture, including, but not limited to broken or leaking pipes, leaking faucet, wet mopping, weather or other natural disasters, is excluded from Signature warranties.
- Use "for hardwood floors" approved cleaning and maintenance products only. Use of non-hardwood floors approved cleaners and maintenance products or any oil, soap, detergent, water, and/or ammonia-based cleaners will void all warranties. For a current list of approved products, please visit our web site at [www.signatureinnovations.com](http://www.signatureinnovations.com).

#### **WARRANTY EXCLUSIONS**

SIGNATURE WARRANTIES DO NOT COVER INDENTATIONS, SCRATCHES, STAINS OR DAMAGE CAUSED BY NEGLIGENCE, FIRE, WATER, MOISTURE, DRYNESS, BROKEN AND/OR LEAKING PIPES AND/OR FAUCETS, FURNITURE OR EQUIPMENT MOVEMENT, DAMAGE CAUSED BY HEAVY ITEMS, BY IMPACT, EXCESSIVE HEAT, EROSION, PEBBLES, SAND OR OTHER ABRASIVES, PETS, INSECTS, WORN OR NARROW-HEELED SHOES, SPIKE HEELED SHOES, HARD ROLLERS, USE OF RUGS WITH SOLID RUBBER OR VINYL BACKINGS, WEATHER CONDITIONS OR NATURAL DISASTERS, COLOR VARIATIONS, NATURALLY OCCURRING WOOD CHARACTERISTICS, IMPROPER INSTALLATION, FAILURE TO FOLLOW WRITTEN INSTALLATION AND/OR MAINTENANCE INSTRUCTIONS, IMPROPER MAINTENANCE, WET MOPPING, INSUFFICIENT PROTECTION, MISUSE OR IMPROPER ALTERATIONS OF THE ORIGINAL MANUFACTURED PRODUCT.

SIGNATURE WARRANTIES DO NOT COVER NATURAL EXPANSION AND CONTRACTION RESULTING IN SEPARATION BETWEEN BOARDS OR DAMAGE CAUSED BY LOW OR EXCESSIVE HUMIDITY.

NO WARRANTIES APPLY TO ANY PRODUCT OR PRODUCTS DESIGNATED AS SECONDS, RUSTIC, CLOSE-OUTS, OFF-GOODS OR NON-STANDARD ITEMS. ANY PRODUCT(S) SO DESIGNATED ARE SOLD "AS IS."

THE ABOVE STATEMENT OF WARRANTY IS THE ONLY WARRANTY, EXPRESSED OR IMPLIED, PROVIDED BY SIGNATURE INNOVATIONS, LLC, FOR ITS BRAND NAME SIGNATURE FLOORBOARDS™, RESIDENTIAL FLOORING PRODUCTS FOR RESIDENTIAL APPLICATIONS INVOLVING LIGHT TO NORMAL TRAFFIC CONDITIONS. NO WARRANTY IS PROVIDED FOR INSTALLATION OF SIGNATURE FLOORBOARDS™ IN COMMERCIAL OR INDUSTRIAL APPLICATIONS.

THERE ARE NO WARRANTIES, WHICH EXTEND BEYOND THE DESCRIPTION ON THE FACE HEREOF. NO OTHER WARRANTIES EXPRESS, IMPLIED, BY OPERATION OF LAW OR OTHERWISE, ARE MADE INCLUDING, BUT NOT LIMITED TO, MERCHANTABILITY OR FITNESS FOR A PARTICULAR PURPOSE. UNDER NO CIRCUMSTANCES SHALL SIGNATURE INNOVATIONS, LLC, BE LIABLE OR ANY MANNER RESPONSIBLE FOR ANY CLAIM, LOSS OR DAMAGE ARISING FROM THE PURCHASE, USE OR INABILITY TO USE THIS PRODUCT, OR FOR ANY SPECIAL INDIRECT, INCIDENTAL OR CONSEQUENTIAL DAMAGES, INCLUDING, WITHOUT LIMITATION, LOST PROFITS, EMOTIONAL, MULTIPLE, PUNITIVE OR EXEMPLARY DAMAGES (SEE BELOW) OR ATTORNEYS FEES, EVEN IF SIGNATURE INNOVATIONS, LLC, OR ITS REPRESENTATIVES HAVE BEEN ADVISED OF THE POSSIBILITY OF SUCH DAMAGES BEFORE SALE. IN NO EVENT SHALL SIGNATURE INNOVATIONS, LLC, BE OBLIGATED TO COVER THE COSTS OF OLD OR NEW MATERIALS OTHER THAN SIGNATURE BRAND FLOORING PRODUCTS (e.g. floor moldings), EVEN IF RECOMMENDED BY SIGNATURE INNOVATIONS, LLC, AND ANY WARRANTY THERETO IS LIMITED TO THE WARRANTY, IF ANY, PROVIDED BY THE ORIGINAL MANUFACTURER. UNDER NO CIRCUMSTANCES SHALL SIGNATURE INNOVATIONS, LLC, LIABILITY EXCEED THE AMOUNT SIGNATURE INNOVATIONS, LLC, ACTUALLY RECEIVED UPON DISTRIBUTION FOR THE DEFECTIVE MATERIALS AT ISSUE. ANY CLAIM FOR WARRANTY COVERAGE MUST BE MADE WITHIN NINETY (90) DAYS OF THE DATE UPON WHICH THE DEFECT FIRST BECAME KNOWN OR FIRST SHOULD HAVE BEEN DISCOVERED. ALL CLAIMS MUST BE MADE IN WRITING. PLEASE NOTE THAT IN ORDER TO MAKE ANY CLAIM UNDER THIS WARRANTY, EVIDENCE OF THE PURCHASE DATE AND THE IDENTITY OF THE ORIGINAL PURCHASER AND INSTALLATION LOCATION MUST BE PROVIDED AND WITHOUT SUCH PROOF, NO WARRANTY COVERAGE WILL APPLY. WE STRONGLY RECOMMEND THAT YOU KEEP THIS INFORMATION TOGETHER WITH INSTALLATION AND MAINTENANCE MANUAL AND YOUR RECEIPT IN A SAFE AND SECURE PLACE.

THIS WARRANTY GIVES YOU SPECIFIC LEGAL RIGHTS AND YOU MAY ALSO HAVE OTHER RIGHTS THAT VARY FROM STATE TO STATE. SOME STATES DO NOT ALLOW LIMITATIONS ON HOW LONG AN IMPLIED WARRANTY LASTS OR THE EXCLUSION OR LIMITATION OF INCIDENTAL OR CONSEQUENTIAL DAMAGES, SO THE ABOVE LIMITATIONS MAY NOT APPLY TO YOU. THE SOLE REMEDY PROVIDED HEREIN IS THE REPAIR, REFINISH, REPLACEMENT OR REFUND OF DEFECTIVE PRODUCTS.



**P.O. Box 464  
Wood Dale, Illinois 60191-0464  
[www.signatureinnovations.com](http://www.signatureinnovations.com)**

**2003 Signature Innovations, LLC.**